

10-TAP DIP/SMD DELAY LINE

$T_D/T_R = 5$
(SERIES 1520)



FEATURES

- 10 taps of equal delay increment
- Delays to 1000ns
- Low profile
- Epoxy encapsulated
- Meets or exceeds MIL-D-23859C

PACKAGES

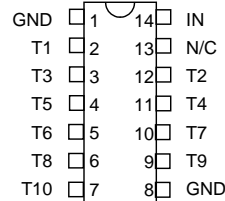

IN Signal Input
T1-T10 Tap Outputs
GND Ground

Note: Standard pinout shown
Other pinouts available

FUNCTIONAL DESCRIPTION

The 1520-series device is a fixed, single-input, ten-output, passive delay line. The signal input (IN) is reproduced at the outputs (T1-T10) in equal increments. The delay from IN to T10 (T_D) and the characteristic impedance of the line (Z) are determined by the dash number. The rise time (T_R) of the line is 20% of T_D , and the 3dB bandwidth is given by $1.75 / T_D$. The device is available in a 14-pin DIP (1520) or a 14-pin SMD (1520S), and a wide range of pinouts may be specified.

Part numbers are constructed according to the scheme shown at right. For example, 1520C-101-500B is a 290 mil DIP, 100ns, 50Ω delay line with pinout code B. Similarly, 1520SB-201-251 is a 240 mil SMD, 200ns, 250Ω delay line with standard pinout.

PART NUMBER CONSTRUCTION

1520(S)m - xxx - zzz p

MOUNTING HEIGHT CODE
See Table

DELAY TIME
Expressed in nanoseconds (ns)
First two digits are significant figures
Last digit specifies # of zeros to follow

IMPEDANCE
Expressed in ohms
First two digits are significant figures
Last digit specifies # of zeros to follow

PINOUT CODE
See Table
Omit for STD pinout

SERIES SPECIFICATIONS

- **Dielectric breakdown:** 50 Vdc
- **Distortion @ output:** 10% max.
- **Operating temperature:** -55°C to +125°C
- **Storage temperature:** -55°C to +125°C
- **Temperature coefficient:** 100 PPM/°C

PINOUT CODES

CODE	IN	T1	T2	T3	T4	T5	T6	T7	T8	T9	T10	GND
STD	14	2	12	3	11	4	5	10	6	9	7	1,8
A	1	2	13	3	12	4	10	5	9	6	7	14
B	2	3	4	5	6	7	9	10	11	12	13	1,14
C	7	9	6	10	5	11	12	3	13	2	14	1,8
D	1	13	2	12	3	11	4	10	5	9	6	7,8,14
E	2	3	4	5	6	7,8	9	10	11	12	13	1,14
F	1	13	2	12	3	11	4	10	5	9	6	7
G	2	13	3	12	4	11	5	10	6	9	7	8,14
H	2	3	4	12	6	7	9	10	11	12	13	1
I	1	13	2	12	3	11	5	10	6	9	7	8,14
J	1	2	13	3	12	4	10	5	9	6	7	8,14
K	1	2	3	4	5	6	12	11	10	9	8	7
L	13	12	11	10	9	7,8	6	5	4	3	2	1,14
N	1	2	3	4	5	6	10	11	12	13	14	7
P	1	13	3	12	4	11	5	10	6	9	7	8,14
T	1	2	3	4	5	6	9	10	11	12	13	7,14
U	2	3	4	5	6	8	9	10	11	12	13	1,7
V	2	3	4	5	6	8	9	10	11	12	13	1
W	1	13	2	12	3	11	4	10	5	9	6	7,14
Z	1	13	3	12	4	11	5	10	6	9	8	7

DELAY SPECIFICATIONS

T_D (ns)	T_1 (ns)	T_R (ns)	ATTENUATION (%) TYPICAL				
			Z=50Ω	Z=100Ω	Z=200Ω	Z=300Ω	Z=500Ω
10	1.0	3.0	3	5	N/A	N/A	N/A
20	2.0	5.5	3	5	5	N/A	N/A
30	3.0	6.5	3	5	5	N/A	N/A
40	4.0	8.0	3	5	5	5	N/A
50	5.0	10.0	3	5	5	5	7
60	6.0	12.0	3	5	5	5	7
75	7.5	15.0	3	5	5	5	7
100	10.0	20.0	3	5	5	7	7
120	12.0	24.0	3	5	6	7	8
150	15.0	30.0	3	5	6	7	8
180	18.0	36.0	4	5	6	7	8
200	20.0	40.0	4	5	6	7	8
220	22.0	44.0	4	5	6	7	8
250	25.0	50.0	4	5	6	7	8
300	30.0	60.0	N/A	5	8	10	10
375	37.5	75.0	N/A	7	8	10	10
500	50.0	100.0	N/A	8	10	12	12
600	60.0	120.0	N/A	N/A	N/A	15	15
750	75.0	150.0	N/A	N/A	N/A	15	20
1000	100.0	200.0	N/A	N/A	N/A	N/A	20

Notes: T_1 represents nominal tap-to-tap delay increment
Tolerance on $T_D = \pm 5\%$ or ± 2 ns, whichever is greater
Tolerance on $T_1 = \pm 5\%$ or ± 1 ns, whichever is greater
“N/A” indicates that delay is not available at this Z

FUNCTIONAL DIAGRAM

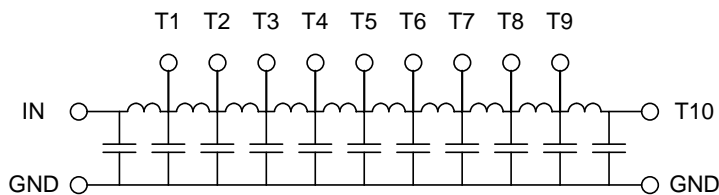

MOUNTING HEIGHT CODES

CODE	HEIGHT (MAX)	DIP	SMD
A	0.187	Yes	No
B	0.240	Yes	Yes
C	0.290	Yes	Yes

Note: Codes A and B are not available for all values of T_D
Contact technical staff for details

PACKAGE DIMENSIONS

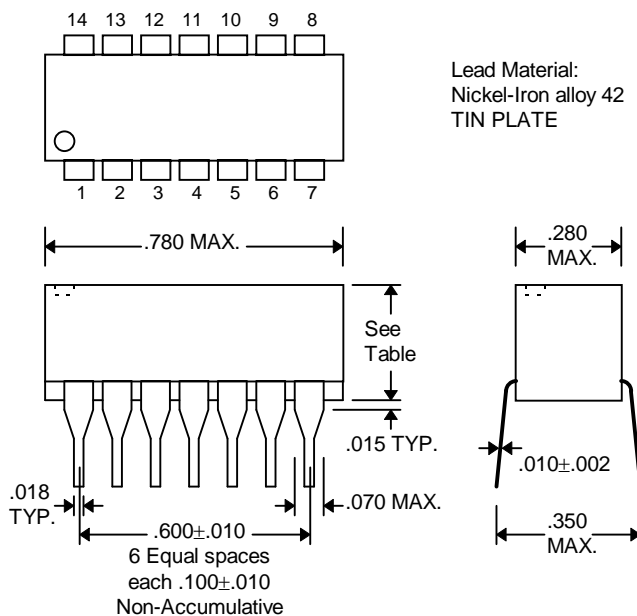

1520-xx (DIP)

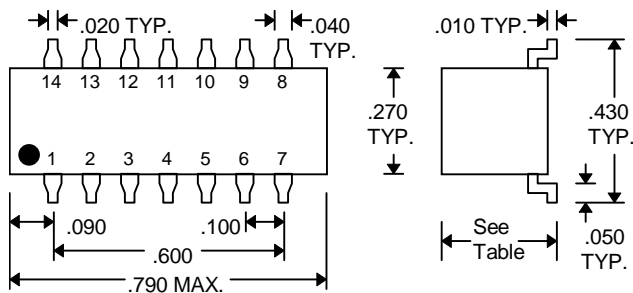

1520S-xx (Gull-Wing)

PASSIVE DELAY LINE TEST SPECIFICATIONS

TEST CONDITIONS

INPUT:		OUTPUT:	
Ambient Temperature:	25°C ± 3°C	R_{load}:	10MΩ
Input Pulse:	High = 3.0V typical Low = 0.0V typical	C_{load}:	10pf
Source Impedance:	50Ω Max.	Threshold:	50% (Rising & Falling)
Rise/Fall Time:	3.0 ns Max. (measured at 10% and 90% levels)		
Pulse Width (T_D ≤ 75ns):	PW _{IN} = 100ns		
Period (T_D ≤ 75ns):	PER _{IN} = 1000ns		
Pulse Width (T_D > 75ns):	PW _{IN} = 2 x T _D		
Period (T_D > 75ns):	PER _{IN} = 10 x T _D		

NOTE: The above conditions are for test only and do not in any way restrict the operation of the device.

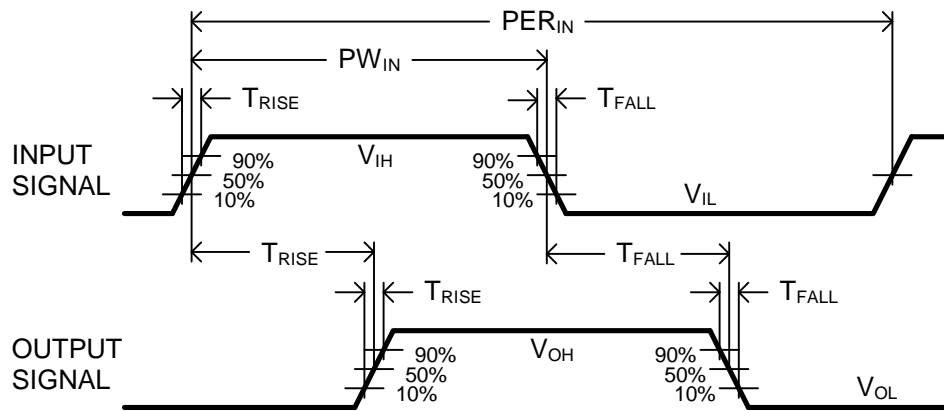

Timing Diagram For Testing

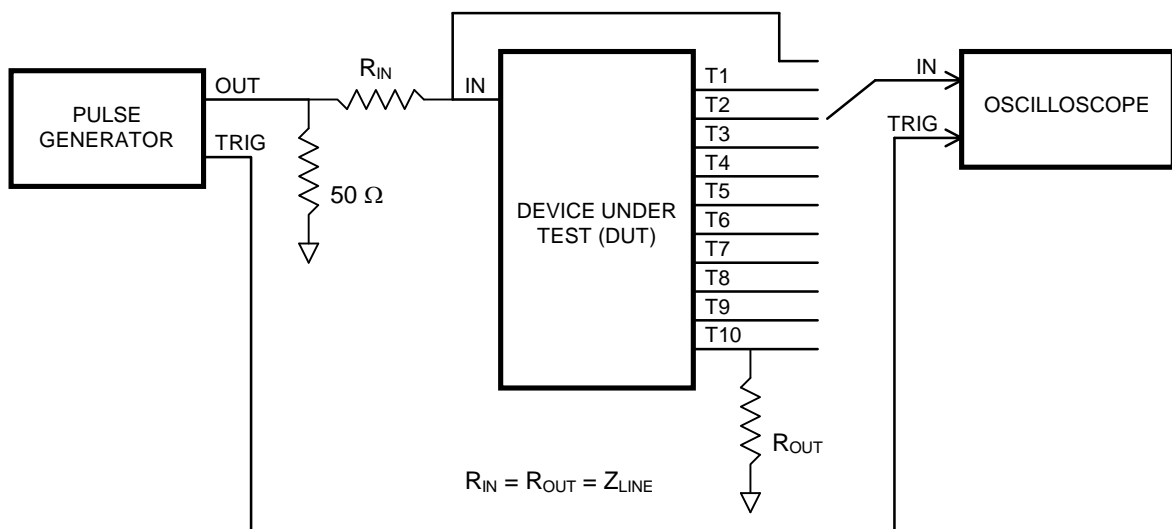

Test Setup